

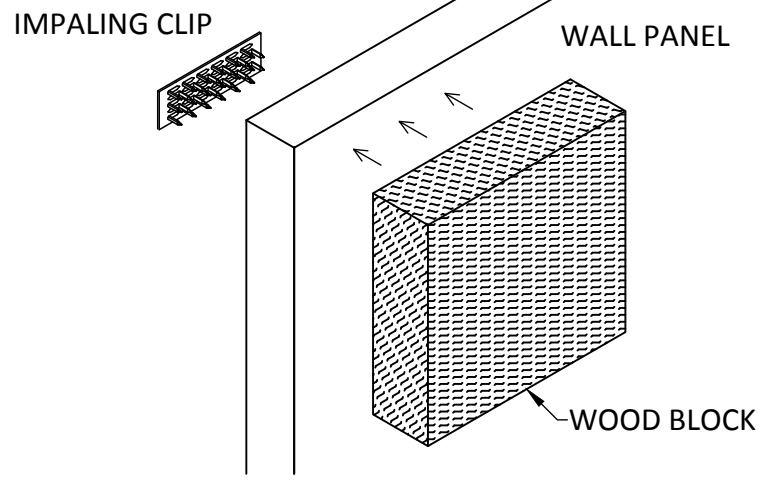

REVISIONS				
ZONE	REV	DESCRIPTION	DATE	APPROVED

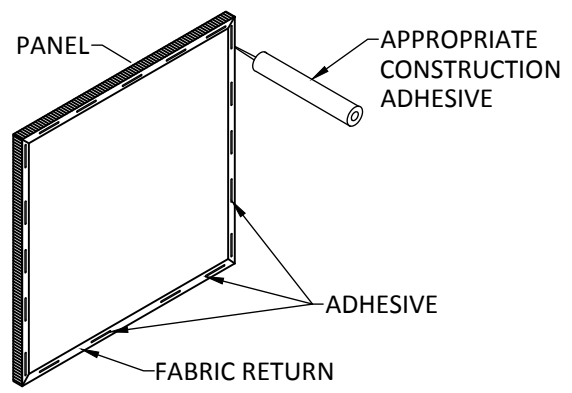
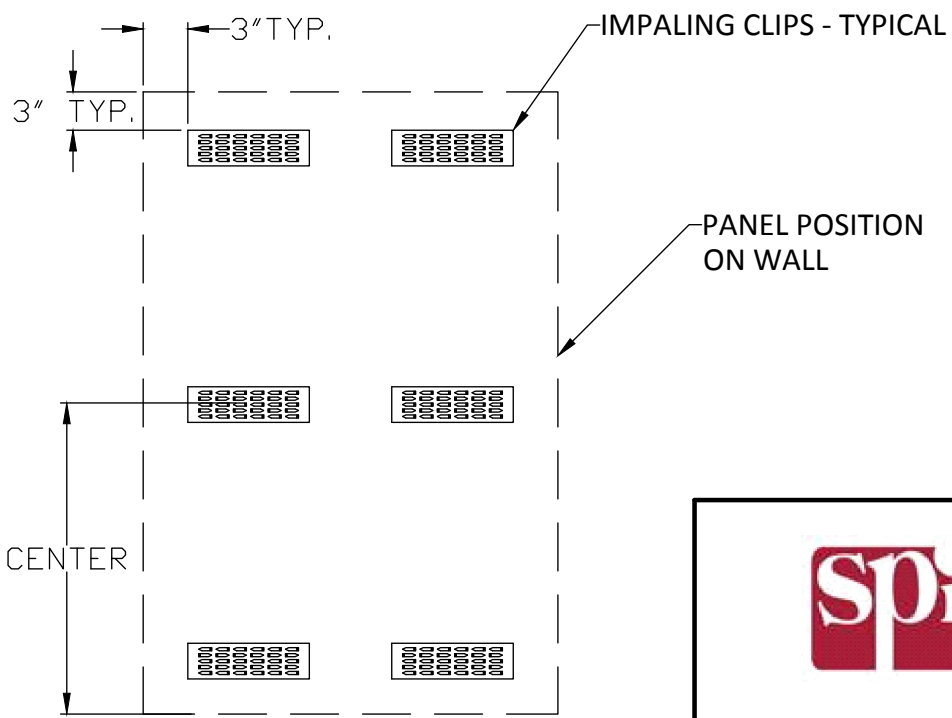

1. DETERMINE WHERE PANELS ARE TO BE INSTALLED
2. SCREW IMPALING CLIPS INTO PLACE ON WALL PER ILLUSTRATION AND TABLE AT RIGHT
3. CLEAN WALL SURFACE AND APPLY CONSTRUCTION ADHESIVE TO PANEL BACK AS SHOWN IN ILLUSTRATION (ADHESIVE TO BE APPLIED TO FABRIC RETURN AREA ONLY)
4. IMPALE ABSORPTION PLUS PANELS ONTO CLIPS. A Mallet and WOODEN BLOCK MAY BE USED TO CAREFULLY FORCE PANEL DOWN ONTO CLIPS PER ILLUSTRATION

PANEL LENGTH	# OF CLIPS
UP TO 24"	4
24" TO 48"	4
48" TO 72"	4 - 6
72" TO 96"	6 - 8
96" TO 120"	8



	ABSORPTION PLUS PANEL IMPACT PANEL		
	INSTALLATION INSTRUCTIONS USING IMPALING CLIPS AND CONSTRUCTION ADHESIVE		
SIZE A	FSCM NO.	DWG NO. 20000362	REV 2
JAN. 12, 2012		SCALE N/A	DRWN ZCH
		SHEET 1 OF 1	